

**Submersible
Electric Pumps
for drainage
of clean and
dirty water
DOC Series**



DOC pumps are versatile, corrosion-resistant and compact. Three basic versions are available with 0,25 to 0,55 kW power.

A DOC 7VX version with Vortex impeller is available.

- The **DOC7** pump features a flow rate up to **225 l/min**, head up to **11 m**, and passes **suspended solids up to 10 mm** in diameter.
- The **DOC7VX** pump features a flow rate up to **175 l/min**, head up to **7 m**, and can handle liquids with **suspended solids up to 20 mm** in diameter.
- **Versions:**
 - Single-phase: 220-240V, 50Hz 2 poles.
 - Three-phase: 220-240V, 50Hz 2 poles. 380-415V, 50Hz 2 poles.
- **The single-phase versions** feature:
 - **pre-assembled float switch** for automatic pump operation.
 - **built-in capacitor.**
 - **thermal overload protection** to stop pump supply in case of overheating.
- SG versions (single-phase without float switch), GT versions (single-phase with pre-assembled tube float switch), 60 Hz single-phase and three-phase versions, versions with various power cord lengths and various plugs are available on request.
- A "**shallow-suction device**", that can be mounted on both the DOC3 and DOC7 models, is available on request. It ensures the complete drainage of flooded floors (down to 3 mm from floor).

APPLICATIONS

- Emptying of residential sump pits, rainwater tanks or laundry drainage.
- Garden and lawn irrigation, with suction from rainwater tanks.
- Emergency draining of flooded basements and garages.
- Transfer of water from tanks and basins.

SPECIFICATIONS

- **Maximum liquid temperature: 40°C.**
- **Dry motor** cooled by the pumped liquid.
- **Power cord:**
 - single-phase: with plug.
 - three-phase: without plug.
- **Insulation class 130°C (B).**
- **IPX8 protection.**
- **Maximum immersion depth: 5 m.**
- The **DOC3** pump features a flow rate up to **135 l/min**, head up to **7 m**, and passes **suspended solids up to 10 mm** in diameter. Only available in single-phase version.

SOS KIT

The **SOS Kit** is available, for quick emergency dewatering of flooded basements, garages and residential buildings.

The kit is composed of:

- a single-phase **DOC3** electric pump, equipped with float switch, 10 meters power cord with plug and a quick coupling already mounted for rapid hose connection.
- 6 meters long **flexible hose**, complete with quick coupling already mounted for rapid pump connection.
- **plastic box** that can be used to store the kit on a shelf when not in use, or as a strainer during operation.

DOC SERIES IDENTIFICATION CODE

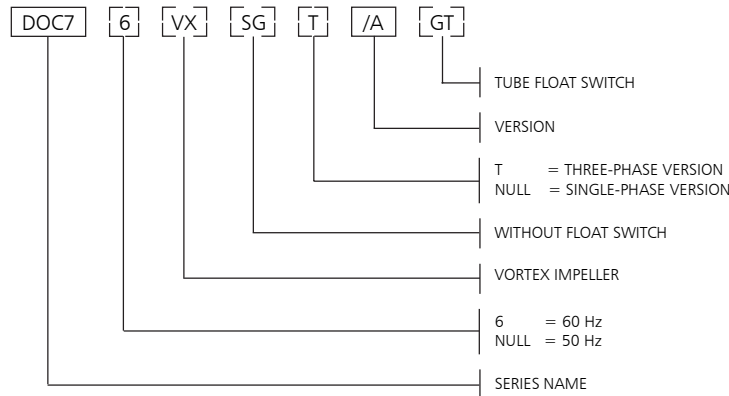

EXAMPLE : DOC 7VX/A
 DOC 7 Series Electric pump, 50 Hz version,
 Vortex impeller, single-phase, /A version.

SINGLE-PHASE RATING PLATE

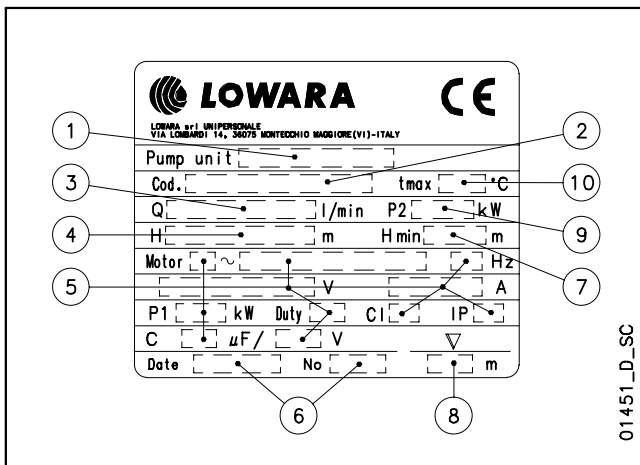

LEGEND

- 1 - Electric pump type
- 2 - Code
- 3 - Delivery range
- 4 - Head range
- 5 - Motor type
- 6 - Date of manufacture and serial number
- 7 - Minimum head
- 8 - Maximum immersion depth
- 9 - Rated output
- 10 - Maximum liquid temperature

THREE-PHASE RATING PLATE

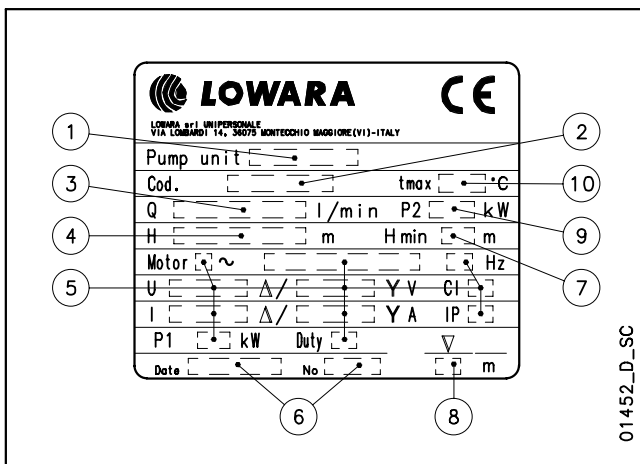

DOC SERIES

LIST OF MODELS AND TABLE OF MATERIALS

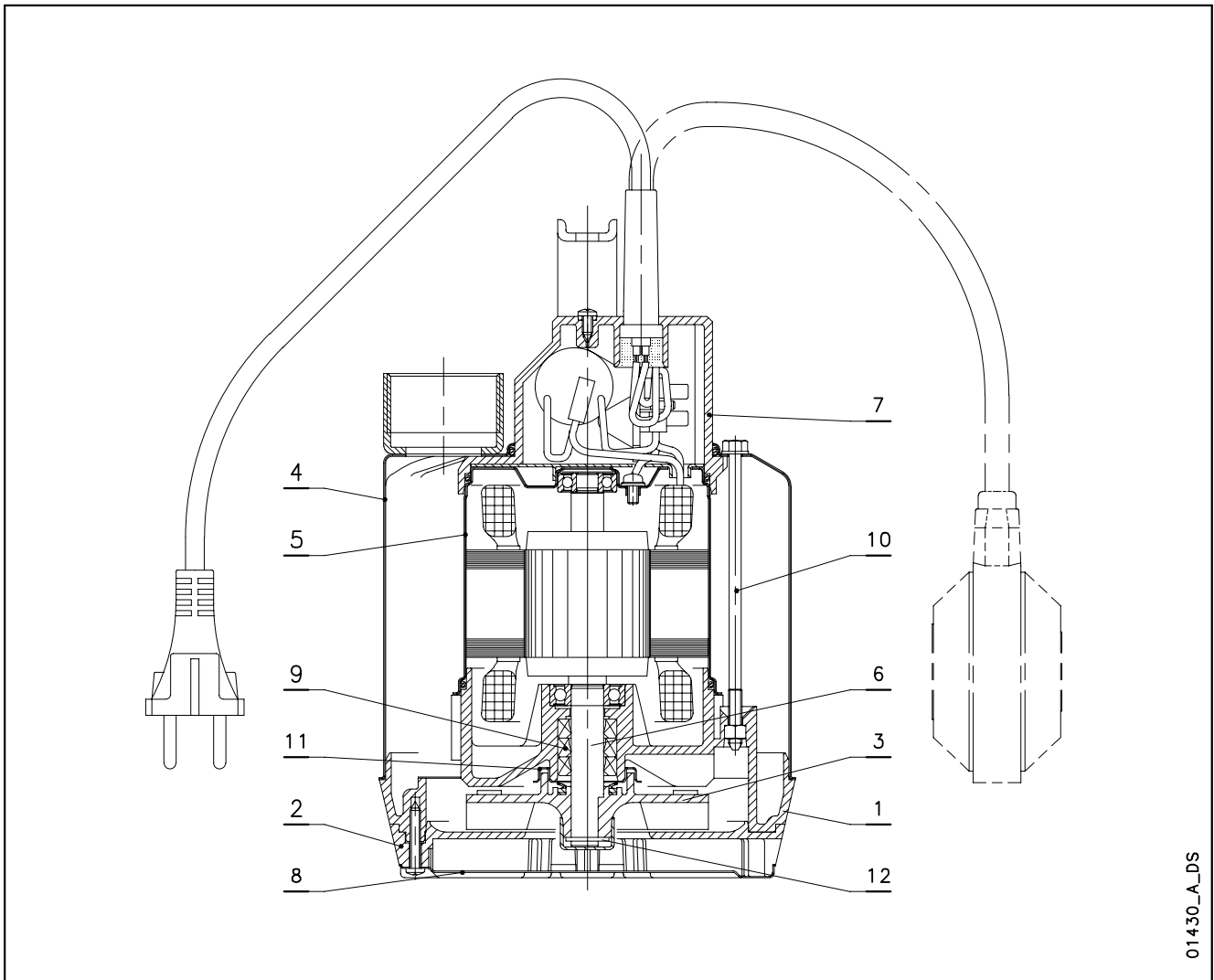

01430_A_DS

REF. N.	NAME	MATERIAL	REFERENCE STANDARDS	
			EUROPE	USA
1	Pump body	PPO resin + 20 % GF		
2	Suction strainer	PPO resin + 20 % GF		
3	Impeller DOC3	PPO resin + 20 % GF		
	Impeller DOC7 - DOC7VX	PA 66 + 30 % GF		
4	External case	Stainless steel	EN 10088-1-X5CrNi18-10 (1.4301)	AISI 304
5	Internal motor casing	Stainless steel	EN 10088-1-X5CrNi18-10 (1.4301)	AISI 304
6	Shaft	Stainless steel	EN 10088-1-X12CrS13 (1.4005)	AISI 416
7	Head	PPO resin + 20 % GF		
8	Lower cover	Stainless steel	EN 10088-1-X5CrNi18-10 (1.4301)	AISI 304
9	Elastomers	NBR		
10	Tie-rod and screws	Stainless steel	EN 10088-1-X5CrNi18-10 (1.4301)	AISI 304
11	Double wear ring	Stainless steel	EN 10088-1-X5CrNi18-10 (1.4301)	AISI 304
12	Impeller fixing ring	Stainless steel	EN 10088-1-X5CrNi18-10 (1.4301)	AISI 304

doc-en_b_tm

DOC SERIES OPERATING CHARACTERISTICS AT 50 Hz

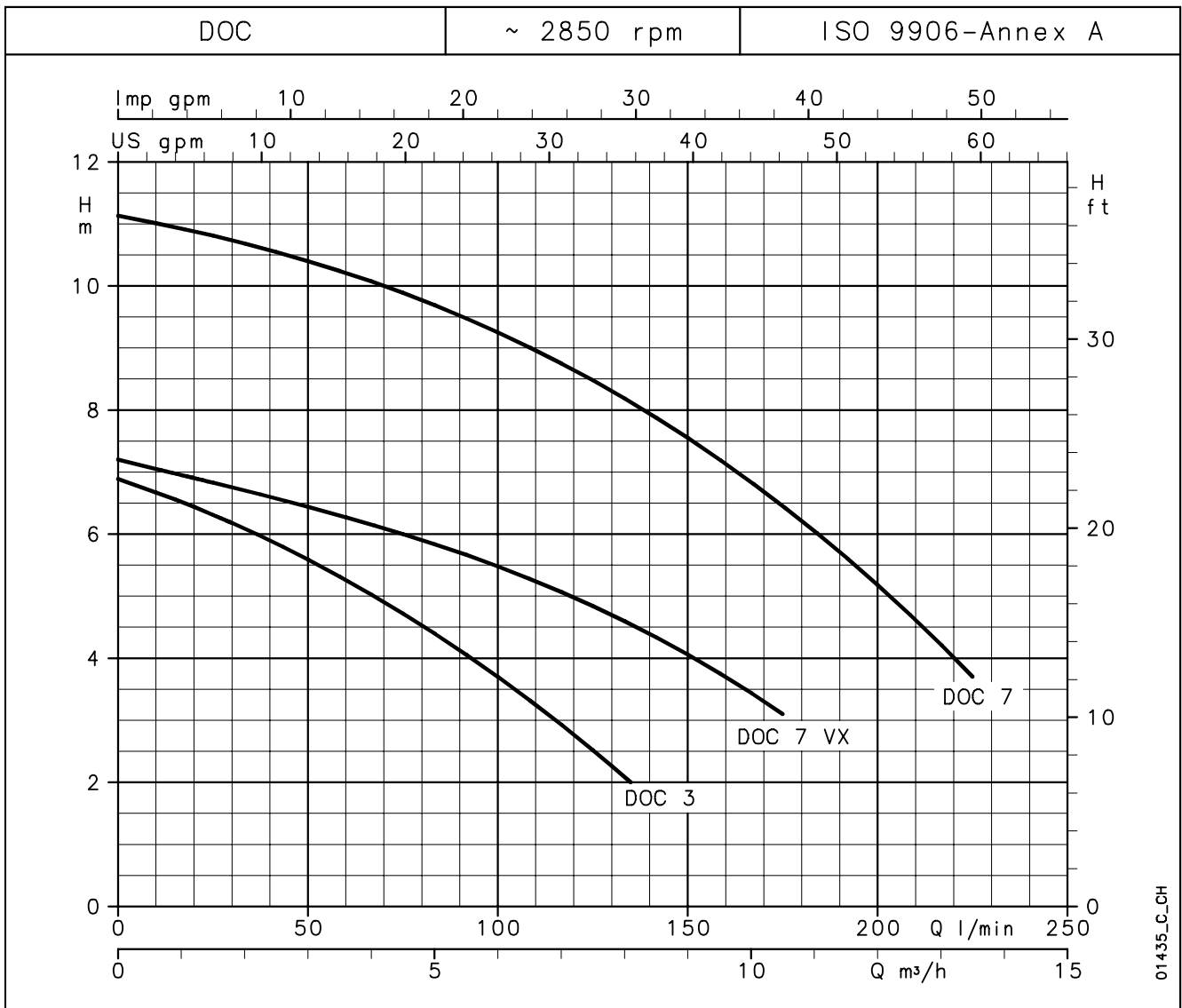

HYDRAULIC PERFORMANCE TABLE

PUMP TYPE	RATED POWER		Q = DELIVERY									
			l/min	0	25	50	75	100	125	135	175	225
			m ³ /h	0	1,5	3	4,5	6	7,5	8,1	10,5	13,5
	kW	HP	H = TOTAL HEAD METRES COLUMN OF WATER									
DOC3	0,25	0,33	6,9	6,3	5,6	4,7	3,7	2,5	2,0			
DOC7(T)	0,55	0,75	11,1	10,8	10,4	9,9	9,3	8,5	8,1	6,5	3,7	
DOC7VX(T)	0,55	0,75	7,2	6,8	6,4	6,0	5,5	4,8	4,5	3,1		

These performances are valid for liquids with density $\rho = 1,0 \text{ kg/dm}^3$ and kinematic viscosity $\nu = 1 \text{ mm}^2/\text{s}$.

doc-2p50-en_b_th

ELECTRICAL DATA TABLE

PUMP TYPE	ABSORBED POWER*	ABSORBED CURRENT*	CAPACITOR
SINGLE-PHASE		220-240 V	
	kW	A	$\mu\text{F} / 450 \text{ V}$
DOC 3	0,31	1,43	6,3
DOC 7	0,78	3,47	16
DOC 7VX	0,66	2,96	16

PUMP TYPE	ABSORBED POWER*	ABSORBED CURRENT*	ABSORBED CURRENT*
THREE-PHASE		220-240 V	380-415 V
	kW	A	A
-	-	-	-
DOC 7T	0,79	2,82	1,63
DOC 7VXT	0,66	2,68	1,55

*Maximum values within operating range

doc-2p50-en_a_te

**DOC SERIES
DIMENSIONS AND WEIGHTS**

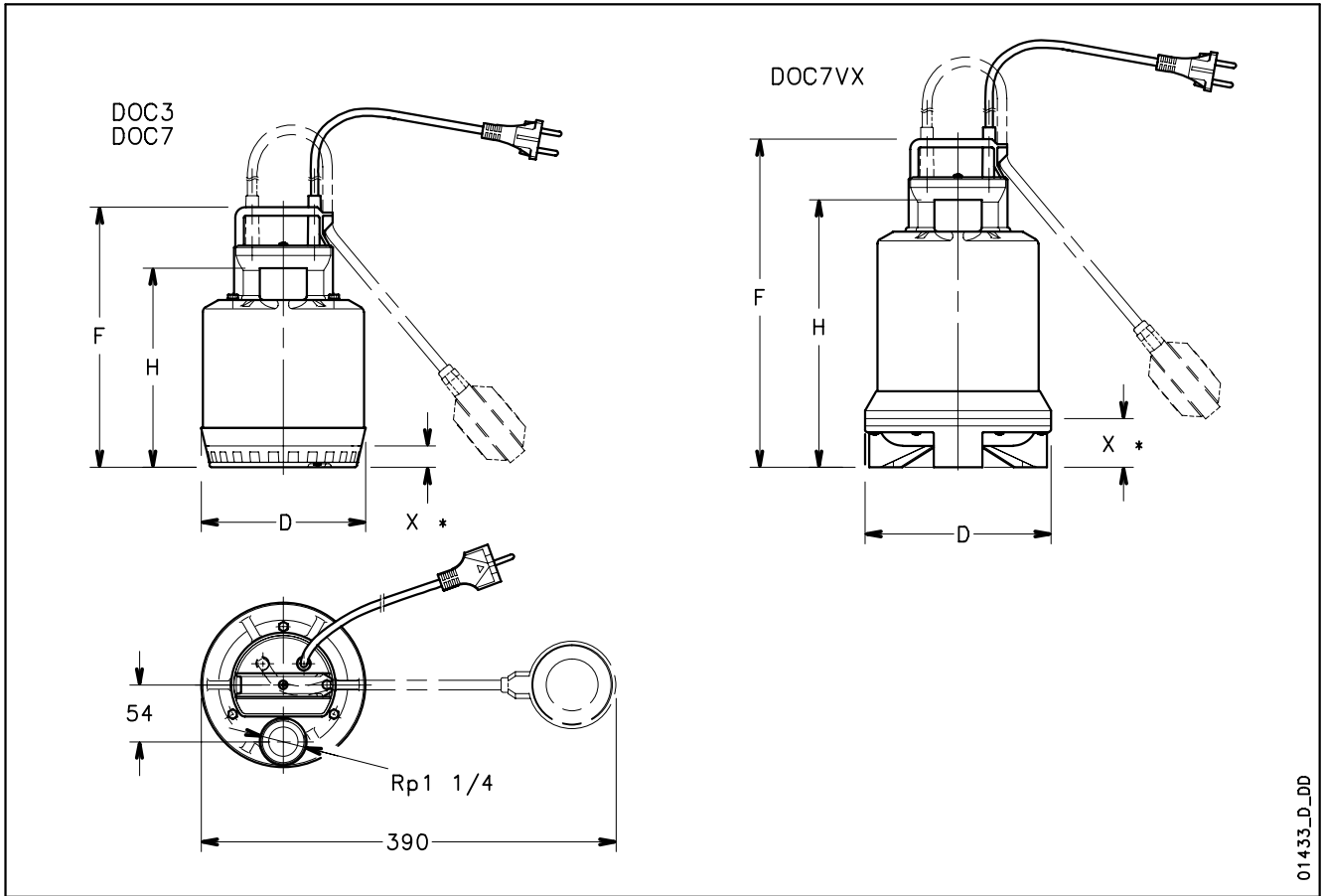

01433_D_DD

PUMP TYPE		DIMENSIONS (mm)				WEIGHT
		F	H	D	X*	kg
DOC3	DOC3 GT	245	188	155	20	4
DOC7(T)	DOC7(T) GT	285	228	155	20	6
DOC7VX(T)	-	310	252	175	45	6

* Minimum liquid level.

doc-2p50-en_b_td

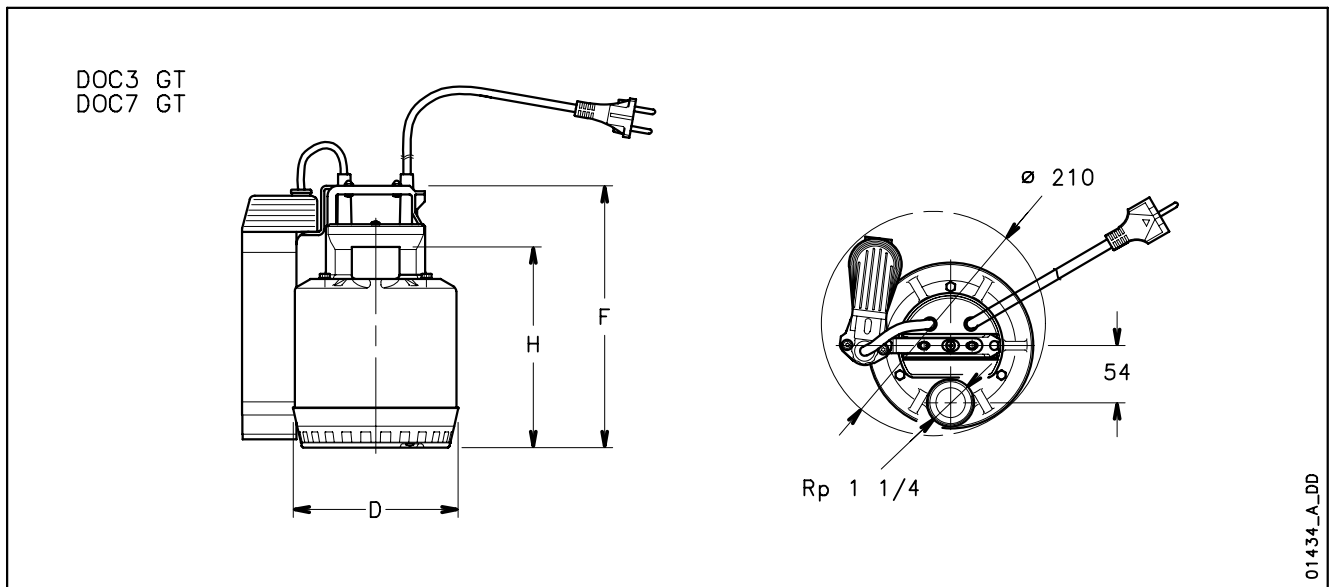

01434_A_DD

**DOC SERIES
INSTALLATION EXAMPLES**

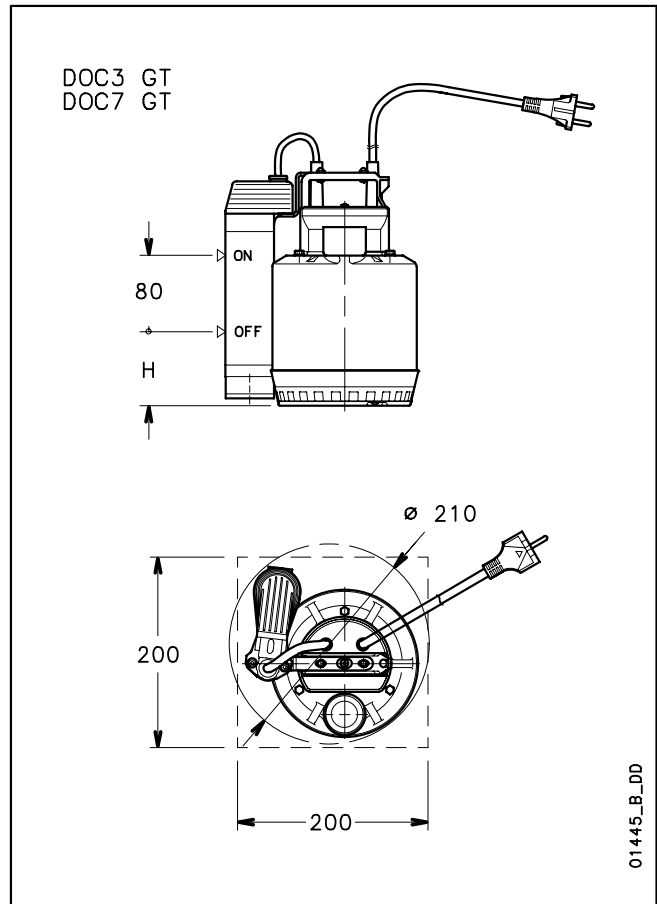
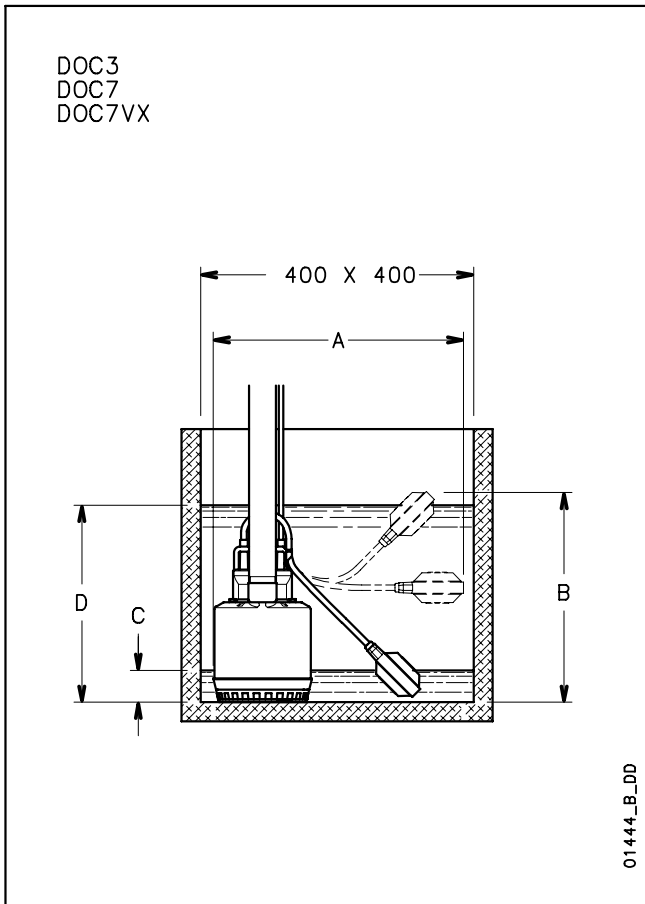

PUMP TYPE		DIMENSIONS (mm)		MINIMUM WATER LEVEL	MAXIMUM WATER LEVEL	MINIMUM WATER LEVEL
		A	B	C*	D*	H
DOC3	DOC3 GT	390	330	50	310	90
DOC7	DOC7 GT	390	370	90	350	90
DOC7VX	-	390	395	115	375	-

* Indicative values depending on the float switch adjustment.

docliv-2p50-en_d_td

ACCESSORIES

