

# CIRCULATORS

## FOR HEATING AND AIR CONDITIONING SYSTEMS



Single body consisting of a cast iron hydraulic unit. Die-cast aluminium motor casing.

Technopolymer impeller. Tempered stainless steel driving shaft mounted on graphite brushings lubricated by the pumped liquid itself.

Stainless steel protective rotor sleeve, stator sleeve and closing flange.

Ceramic thrust bearing, E.P.D.M. O-rings and brass air outlet cap.

The two-pole asynchronous motor with wet rotor is self-protected for resistance.

**No overload protection required. Three-speed operation.**

In the twin version an automatic clapet type valve is provided.

**Operating range:** from 0.5 to 4 m<sup>3</sup>/h with head up to 6.3 metres.

**Liquid temperature range:** from -10°C to +110°C.

**Pumped liquid characteristics:** clean, free from solids and mineral oils, non viscous, chemically neutral, close to the characteristics of water (max 30% glycol).

**Maximum working pressure:** 10 bar (1000 kPa).

**Protection level:** corresponding to IP 44

**Insulation class:** F

**Cable grommet:** PG 11

**Installation:** with motor axis horizontal.

## ELECTRICAL AND HYDRAULIC DATA

### SINGLE WITH UNIONS

MODEL	VOLTAGE 50 Hz	CENTRE DISTANCE mm	UNIONS ON REQUEST		ELECTRICAL DATA						MINIMUM HEAD PRESSURE
			STANDARD	SPECIAL	SPEED	n r.p.m.	P1 MAX W	I <sub>n</sub> A	CAPACITOR		
									μF	V <sub>c</sub>	
VA 25/130	1x230 V ~	130	1" F	3/4" F - 1 1/4" M	3	2590	57	0.26	1,5	450	t° +90°C m.c.a. 1,5
					2	2320	50	0.24			
					1	1895	38	0.18			
VA 25/180	1x230 V ~	180	1" F	3/4" F - 1 1/4" M	3	2590	57	0.26	1,5	450	t° +90°C m.c.a. 1,5
					2	2320	50	0.24			
					1	1895	38	0.18			
VA 25/180 X	1x230 V ~	180	1 1/4" F	-	3	2590	57	0.26	1,5	450	t° +90°C m.c.a. 1,5
					2	2320	50	0.24			
					1	1895	38	0.18			
VA 35/130	1x230 V ~	130	1" F	3/4" F - 1 1/4" M	3	2370	71	0.31	2	450	t° +90°C m.c.a. 1,5
					2	1910	60	0.28			
					1	1440	44	0.2			
VA 35/130 1/2"	1x230 V ~	130	-	-	3	2370	71	0.31	2	450	t° +90°C m.c.a. 1,5
					2	1910	60	0.28			
					1	1440	44	0.2			
VA 35/180	1x230 V ~	180	1" F	3/4" F - 1 1/4" M	3	2370	71	0.31	2	450	t° +90°C m.c.a. 1,5
					2	1910	60	0.28			
					1	1440	44	0.2			
VA 35/180 X	1x230 V ~	180	1 1/4" F	-	3	2370	71	0.31	2	450	t° +90°C m.c.a. 1,5
					2	1910	60	0.28			
					1	1440	44	0.2			
VA 55/130	1x230 V ~	130	1" F	3/4" F - 1 1/4" M	3	2330	82	0.36	2,5	450	t° +90°C m.c.a. 1,5
					2	1815	64	0.29			
					1	1330	45	0.2			
VA 55/130 1/2"	1x230 V ~	130	-	-	3	2330	82	0.36	2,5	450	t° +90°C m.c.a. 1,5
					2	1815	64	0.29			
					1	1330	45	0.2			
VA 55/180	1x230 V ~	180	1" F	3/4" F - 1 1/4" M	3	2330	82	0.36	2,5	450	t° +90°C m.c.a. 1,5
					2	1815	64	0.29			
					1	1330	45	0.2			
VA 55/180 X	1x230 V ~	180	1 1/4" F	-	3	2330	82	0.36	2,5	450	t° +90°C m.c.a. 1,5
					2	1815	64	0.29			
					1	1330	45	0.2			
VA 65/130	1x230 V ~	130	1" F	3/4" F - 1 1/4" M	3	2100	102	0.45	2,5	450	t° +90°C m.c.a. 2,5
					2	1460	78	0.35			
					1	1050	51	0.24			
VA 65/130 1/2"	1x230 V ~	130	-	-	3	2100	102	0.45	2,5	450	t° +90°C m.c.a. 2,5
					2	1460	78	0.35			
					1	1050	51	0.24			
VA 65/180	1x230 V ~	180	1" F	3/4" F - 1 1/4" M	3	2100	102	0.45	2,5	450	t° +90°C m.c.a. 2,5
					2	1460	78	0.35			
					1	1050	51	0.24			
VA 65/180 X	1x230 V ~	180	1 1/4" F	-	3	2100	102	0.45	2,5	450	t° +90°C m.c.a. 2,5
					2	1460	78	0.35			
					1	1050	51	0.24			

### VA 25

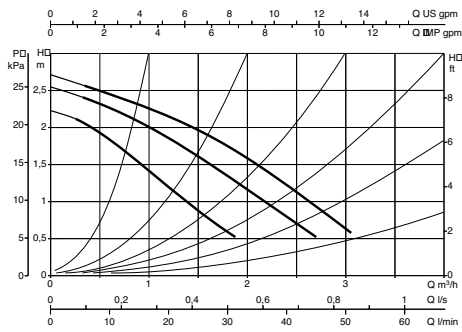

### VA 35

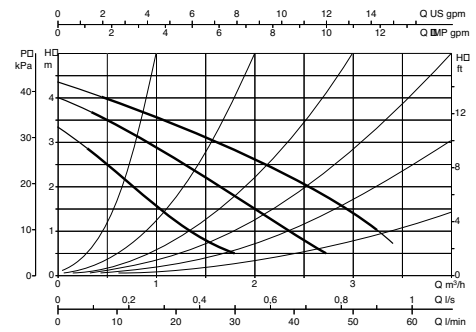

### VA55

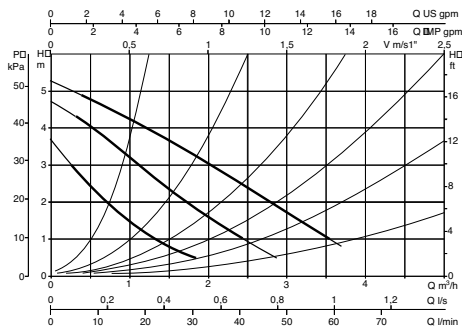

### VA 65

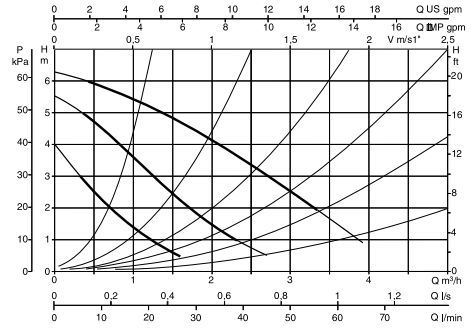

## DIMENSIONS AND WEIGHTS

### VA 25 - 35 - 55 - 65

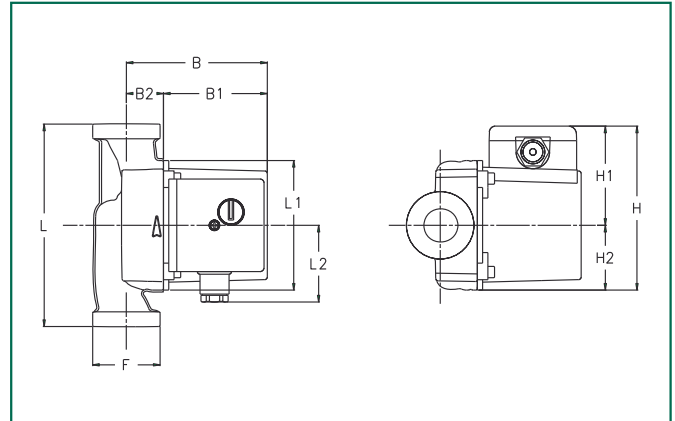

MODEL	L	L1	L2	B	B1	B2	H	H1	H2	D	D1	D2	D4	D5	I	F	PACKAGING DIMENSIONS			VOLUME m <sup>3</sup>	WEIGHT Kg	
																	L	B	H			
<b>VA 25/130</b>	130	98	60	104	78	26	124	75	49	-	-	-	-	-	-	1 1/2" G	138	140	135	0,0026	2,65	
<b>VA 25/180</b>	180	98	60	104	78	26	124	75	49	-	-	-	-	-	-	1 1/2" G	138	140	135	0,0036	2,8	
<b>VA 25/180 X</b>	180	98	60	104	78	26	124	75	49	-	-	-	-	-	-	2" G	138	190	140	0,0036	2,8	
<b>VA 35/130</b>	130	98	60	104	78	26	124	75	49	-	-	-	-	-	-	1 1/2" G	138	140	135	0,0026	2,65	
<b>VA 35/180</b>	180	98	60	104	78	26	124	75	49	-	-	-	-	-	-	1 1/2" G	138	190	140	0,0036	2,8	
<b>VA 35/180 X</b>	180	98	60	104	78	26	124	75	49	-	-	-	-	-	-	2" G	138	190	140	0,0036	2,8	
<b>VA 55/130</b>	130	98	60	104	78	26	124	75	49	-	-	-	-	-	-	1 1/2" G	138	140	135	0,0026	2,65	
<b>VA 55/180</b>	180	98	60	104	78	26	124	75	49	-	-	-	-	-	-	1 1/2" G	138	190	140	0,0036	2,8	
<b>VA 55/180 X</b>	180	98	60	104	78	26	124	75	49	-	-	-	-	-	-	2" G	138	190	140	0,0036	2,9	
<b>VA 65/130</b>	130	98	60	104	78	26	124	75	49	-	-	-	-	-	-	1 1/2" G	138	190	140	0,0036	2,65	
<b>VA 65/180</b>	180	98	60	104	78	26	124	75	49	-	-	-	-	-	-	1 1/2" G	185	150	150	0,0036	3,15	
<b>VA 65/180 X</b>	180	98	60	104	78	26	124	75	49	-	-	-	-	-	-	2" G	185	150	150	0,0036	3,15	