

HF Centrifugal pumps

Medium range

-  Clean water
-  Agricultural use
-  Industrial use

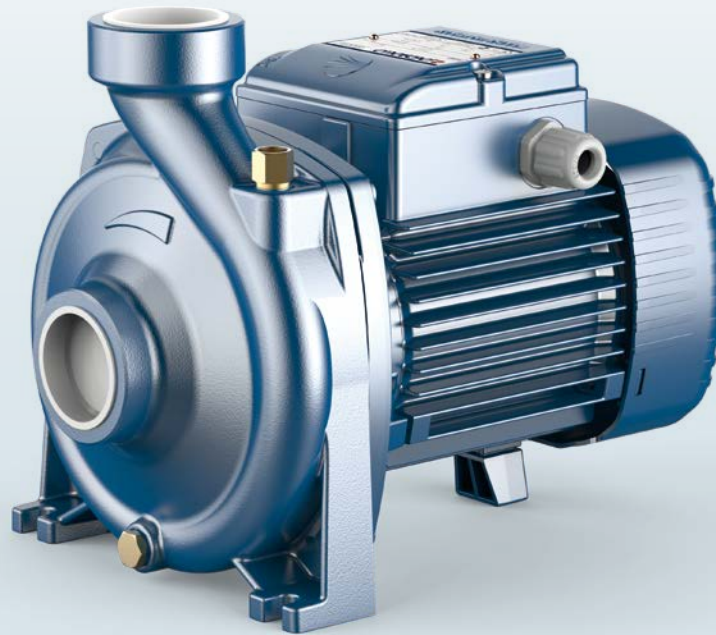

PERFORMANCE RANGE

- Flow rate up to **700 l/min** (42 m³/h)
- Head up to **39 m**

INSTALLATION AND USE

Designed for civil and agricultural use.

Their high-efficiency levels and capability for continuous operation make them an ideal choice for furrow and sprinkler irrigation, in addition to drawing water from lakes, rivers, and wells. They are also suitable for a wide range of industrial applications that require substantial flow rates at medium-low head pressures.

ELECTRIC MOTOR

The three-phase pumps are equipped with newly developed electric motors designed to work with inverters, which guarantee stable and quiet operation.

Efficiency class **IE3** for three-phase motors and **IE2** for single-phase motors, with class F insulation and IPX4 protection.

APPLICATION LIMITS

- Manometric suction head up to **7 m**
- Liquid temperature between **-10 °C** and **+90 °C**
- Ambient temperature up to **+40 °C**
- Maximum working pressure:
 - **6 bar** for HF 5-50-51
 - **10 bar** for HF 5M-70

AVAILABLE UPON REQUEST

- ✘ Mechanical seal options available
- ✘ Different voltage requirements 60 Hz frequency
- ✘ IP X5 protection for HF 5M-70

ABSORPTION

TYPE	VOLTAGE
Single-ph.	230 V
HFm 50B	2.8 A
HFm 50A	3.8 A
HFm 51B	4.7 A
HFm 51A	5.6 A
HFm 70C	8.0 A
HFm 70B	10.0 A
HFm 5B	5.0 A
HFm 5A	6.0 A
HFm 5BM	7.7 A
HFm 5AM	10.1 A
HFm 5ARM	11.5 A

TYPE	VOLTAGE	
	230 V - Δ	400 V - 人
Three-ph.		
HF 50B	2.1 A	1.2 A
HF 50A	2.9 A	1.7 A
HF 51B	3.6 A	2.1 A
HF 51A	4.3 A	2.5 A
HF 70C	6.1 A	3.5 A
HF 70B	7.4 A	4.3 A
HF 70A	9.5 A	5.5 A
HF 5B	3.6 A	2.1 A
HF 5A	4.0 A	2.3 A
HF 5BM	5.7 A	3.3 A
HF 5AM	7.1 A	4.1 A
HF 5ARM	8.0 A	4.6 A

DIMENSIONS AND WEIGHT

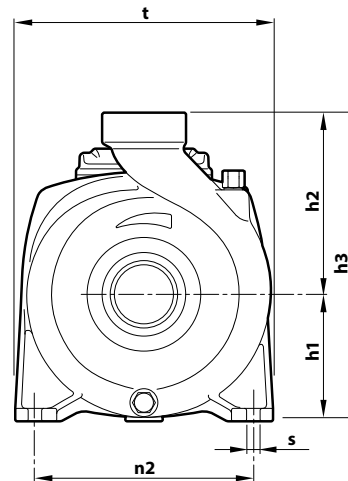
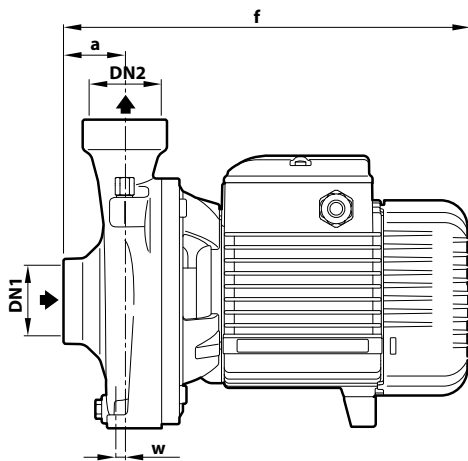

TYPE		PORTS		DIMENSIONS mm									kg		
Single-ph.	Three-ph.	DN1	DN2	a	f	h1	h2	h3	t	n2	w	s	1~	3~	
HFm 50B	HF 50B	1½"	1½"	42	270	82	118	200	166	135	-8	10	8.1	8.1	
HFm 50A	HF 50A												8.9	8.2	
HFm 51B	HF 51B			45	303	92	133	225	190	160	2		12.9	12.7	
HFm 51A	HF 51A												13.2	13.2	
HFm 70C	HF 70C			48.5	373	114	155	269	216	171	12		12	20.0	20.0
HFm 70B	HF 70B													21.5	21.5
-	HF 70A	393	-									24.3			
HFm 5B	HF 5B	2"	2"	43	316	97	141	238	192	160	-68	10	14.1	14.1	
HFm 5A	HF 5A												15.1	14.1	
HFm 5BM	HF 5BM			59	386	110	150	260	208	12.5	11		20.3	20.3	
HFm 5AM	HF 5AM												21.8	21.8	
HFm 5ARM	HF 5ARM			406	-	24.6	24.6								

MATERIALS AND COMPONENTS

1 Pump body Cast iron with ISO 228/1 threaded ports

2 Cover Stainless steel **AISI 304** (cast iron for HF 5M-70)

3 Impeller Stainless steel **AISI 304** (HF50 Start of production 06.2024)
 (HF51 Start of production 06.2024)
 (HF70 Start of production 04.2024)
 (HF5ARM Start of production 06.2024)

4 Mechanical seal	Water pump	Seal	Shaft	Materials
	HF 50	AR-12	Ø 12 mm	Ceramic / Graphite / NBR
	HF 5-51	AR-14	Ø 14 mm	Ceramic / Graphite / NBR
	HF 5M-70	FN-18	Ø 18 mm	Graphite / Ceramic / NBR

5 Motor shaft Stainless steel **AISI 431**

6 Electric motor **HFm**: single-phase 230 V - 50 Hz with winding integrated thermal motor protection
HF: three-phase 230/400 V - 50 Hz
 ※ Pumps are equipped with high-efficiency motors (IEC 60034-30-1)
 class **IE2** for single-phase models
 class **IE3** for three-phase models
 Continuous running duty **S1**

