

Bombas Aquasphere SSP

75M / 100M / 150M

AQUA
SPHERE

DESCRIPCIÓN DEL PRODUCTO

- Gama de bombas autoaspirantes para piscinas residenciales.
- Incluye un prefiltro de 1,6 litros y acoplamiento D50 mm.
- Motores monofásicos, protección IP-X5 y clase de aislamiento F.
- Rango de caudal de 12,5 a 19,5 m³/h a 10 m.c.w.



DATOS TÉCNICOS

Código	Modelo	Tensión	Caudal nominal a H _N	Altura nominal	Altura máx.	Caudal máx. a 4 m de altura	Potencia nominal del motor	Potencia absorbida máx.	Clase de energía
		U _N (V)	Q _N (m ³ /h)	H _N (m)	H _{MAX} (m)	Q _{MAX} (m ³ /h)	P _{2N} (kW)	P _{1MAX} (kW)	EN17645
75939	75M	230*	12,5	10	14,7	18,5	0,55	0,9	D
75940	100M	230*	16	10	17,1	21,7	0,75	1,2	D
75941	150M	230*	19,5	10	17,3	26,3	1,10	1,4	D

* ± 10%

RENDIMIENTO

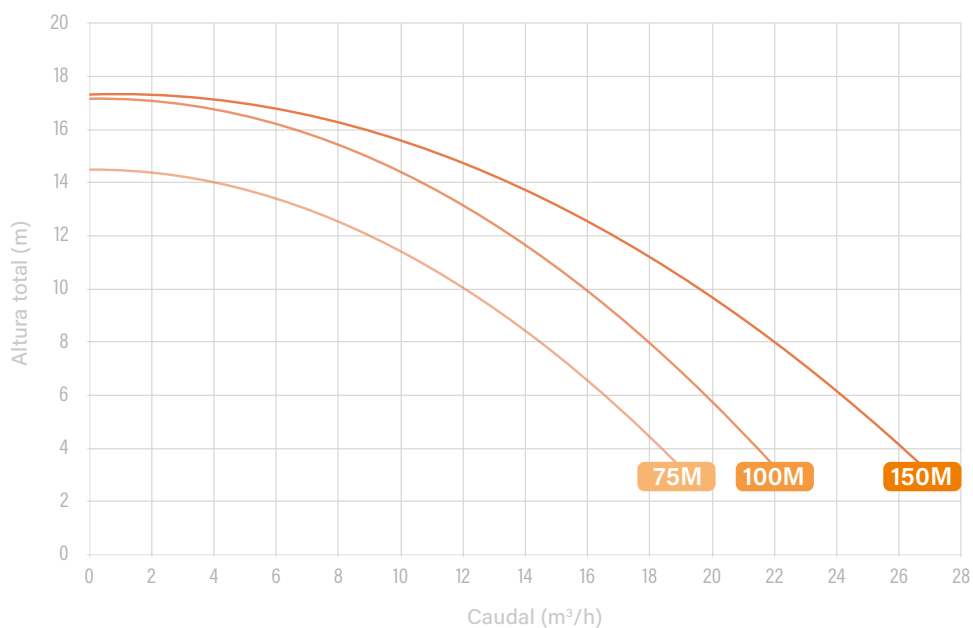

Bombas Aquasphere SSP

75M / 100M / 150M

AQUA
SPHERE

DIMENSIONES Y LOGÍSTICA

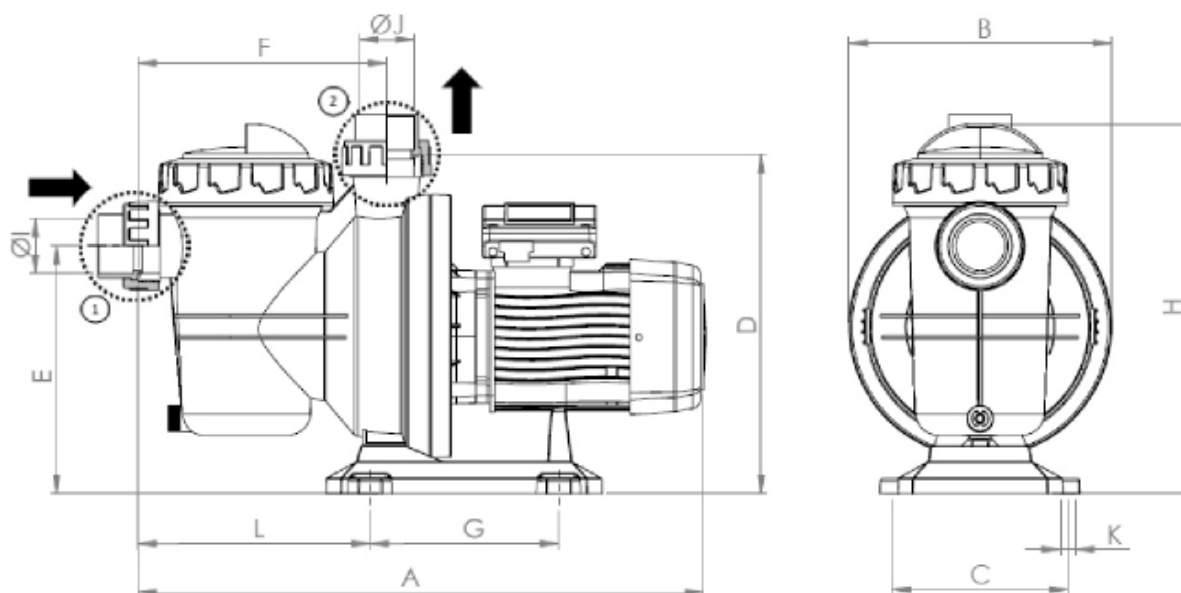

Código	Dimensiones del producto (mm)												Embalaje	
	A	B	C	D	E	F	G	H	I	J	K	L	kg	m ³
75939	514	238	160	307	226	223	170	330	Ø50	Ø50	4u x Ø10	209	9,3	0,054
75940	514	238	160	307	226	223	170	330	Ø50	Ø50	4u x Ø10	209	10,4	0,054
75941	532	238	160	307	226	223	170	330	Ø50	Ø50	4u x Ø10	209	11,8	0,056

A Fluidra Brand

©2024 Fluidra. All rights reserved. All trademarks and trade names used herein are the property of their respective owners.

Bombas de velocidad simple 75M / 100M / 150M